

深圳市新宇瑞通科技有限公司

产品规格书
SPECIFICATION

客户名称: _____

Customer Name

产品类型: 侧面发射管

Product Name

产品型号: RT-XY-IR1206C-010-CT2

Part No.

<input type="checkbox"/> 技术参考 Technical Reference		<input type="checkbox"/> 样品 Sample		<input type="checkbox"/> 量产供货 Mass Product	
客户审核 (加盖公章)			审核		
核准 Approval	确认 Checked	核准 Approval	确认 Checked	制作 Edited	
<input type="checkbox"/> 接收 Qualified			<input type="checkbox"/> 不接收 Disqualified		日期 Date:



RT-XY-IR1206C-010-CT2 它具有体积小发射功率强、发光角度均匀、散热快等优点，该款器件适用于可视门铃，安防监控等其应用。

RT-XY-IR1206C-010/CT2 has the advantages of compact size, strong emission power, uniform light reception angle, fast heat dissipation and so on. This device is suitable for visual doorbell, security monitoring applications.

特性 Features

- 峰值波长 940nm Peak wavelength $\lambda_p=940\text{nm}$
- 高可靠性 High reliability
- 低功耗 Low Power Consumption
- 符合 RoHS compliant RoHS

应用 Applications

- 红外应用系统 Infrared applications systems
- 工业设备 Industrial equipment
- 红外相机 Infrared Illumination for cameras
- 机器视觉系统 Machine visual systems
- 安防监控 security monitoring

产品外型尺寸 Package outline dimensions

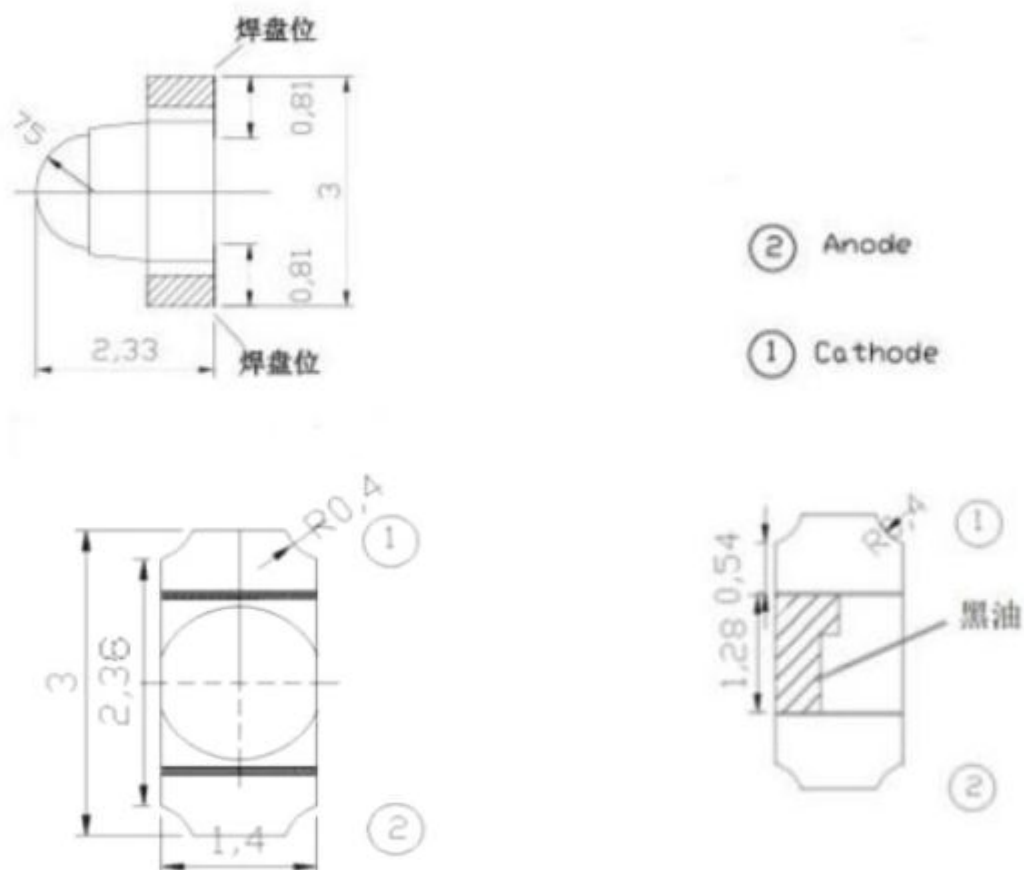

备注：所有尺寸单位均为 mm，如无特殊说明误差范围为±0.15mm

Note : All dimensions in mm, tolerance is ±0.15mm unless otherwise noted

额定参数 Absolute Maximum Ratings(Ta=25°C)

电气特性 Electrical characteristics	符号 Symbol	额定值 Rated Value	单位 Unit
最大持续工作电流 Max continuous working current	IF	100	mA
最大脉冲工作电流* Max pulse current	IFP	500	mA
反向击穿电压 Reverse breakdown voltage	VR	5	V
最大功耗 Power dissipation	Pd	160	mW
工作温度 Operating Temperature	Topr	-40--+85	°C
储存温度 Storage Temperature	Tstg	-40--+100	°C

Note : * Pulse width \leq 100 μ s, Duty \leq 1%

光电特性 Elector-Optical Characteristics (Ta=25°C)

参数 Parameter	符号 Symbol	测试条件 Test Condition	最小 Min	典型 Type	最大 Max	单位 Unit
峰值波长 Peak wavelength	λ_p	IF=100mA	--	940	--	nm
光功率 luminous power	Po	IF=100mA	--	50	--	mW
辐射强度 Radiant Intensity	Ie	IF=20mA	12	15	17	mW/sr
工作电压 Forward Voltage	VF	IF=20mA	--	1.1	1.3	V
反向电流 Reverse current	IR	VR=5V	--	--	10	μ A
发射角度 Emission Angle	2 $\theta_{1/2}$	IF=100mA	--	20	--	Deg.

可靠性试验 Reliability Test

测试项目 Test Parameter	参考标准 Reference Criterion	测试条件 Test Condition	时间 Time	样品数 Quantity	Ac/Re
耐焊接热 Resistance to Soldering Heat	JESD22-B106	245°C±5°C	5 sec	22PCS	0/1
冷热冲击 Thermal Shock	JESD22-A104	+105°C(30min)5min -40°C(30min)	100 cycles	22PCS	0/1
高温贮存 High Temperature storage	JESD22-A103	+100°C	1000H	22PCS	0/1
低温贮存 Low Temperature storage	JESD22-A119	-40°C	1000H	22PCS	0/1
寿命测试 Life Test	JESD22-A108	IF=100mA	1000H	22PCS	0/1
高温高湿 High Temperature High Humidity	JESD22-A101	TC=85°C RH=85%	1000H	22PCS	0/1

光电特性曲线 Typical electro-optical characteristics curves

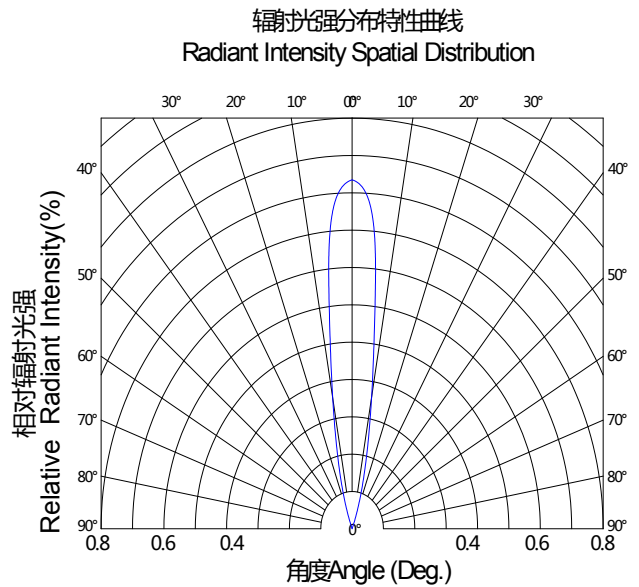
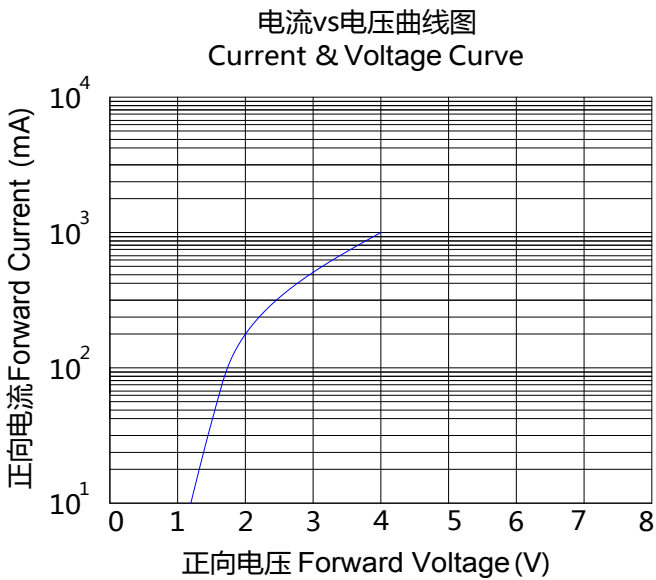
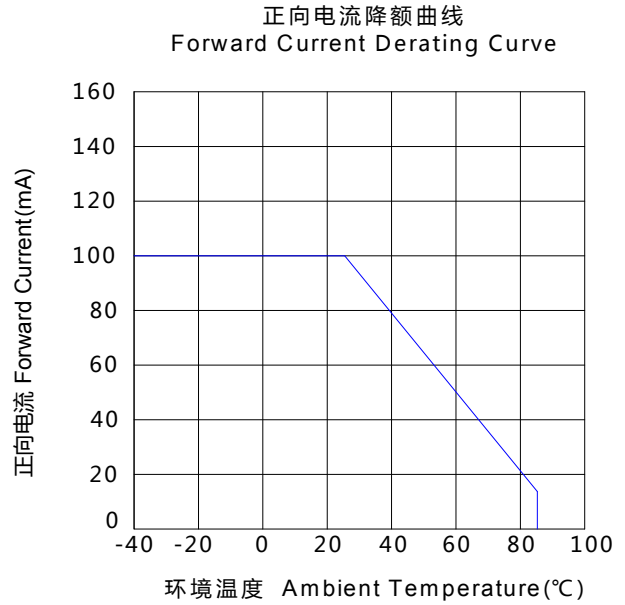
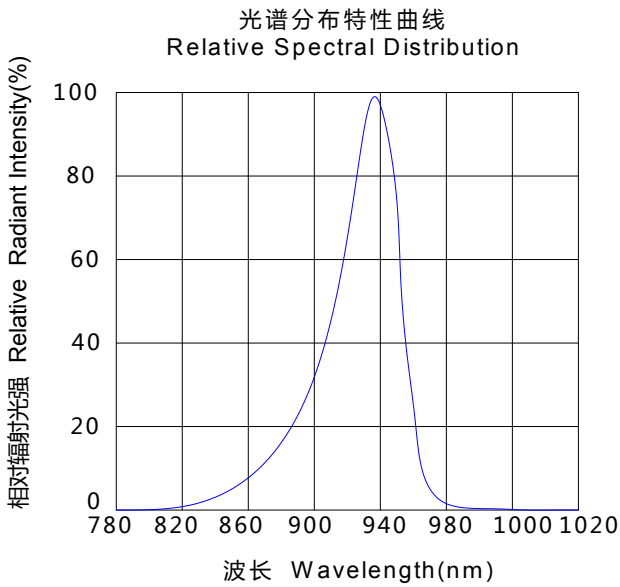

包装规格 Packing Specification

■ 载带规格 Carrier Tape

编带 2000pcs/卷 Quantity 2000 pcs Per Scroll

编带产品前空 50pcs , 后空≥100pcs

包装方式:

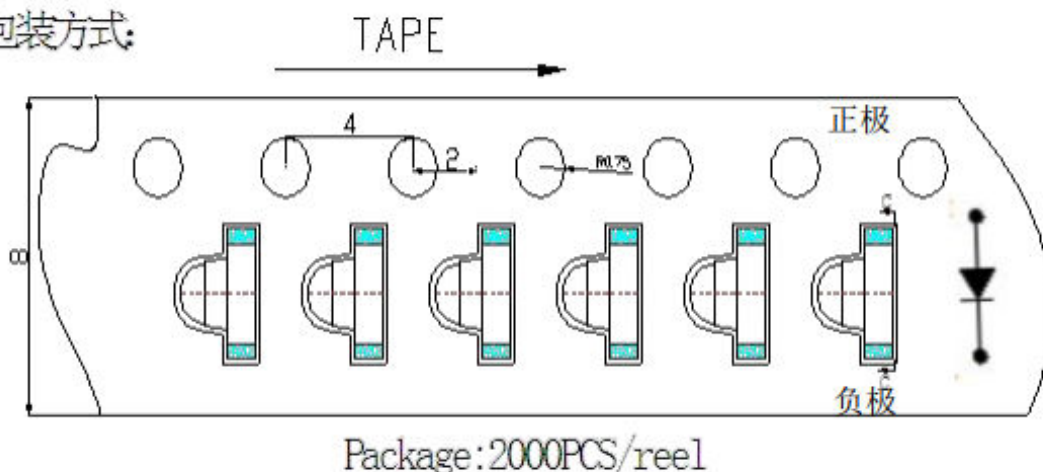

■ 卷轴尺寸 Reel Dimensions

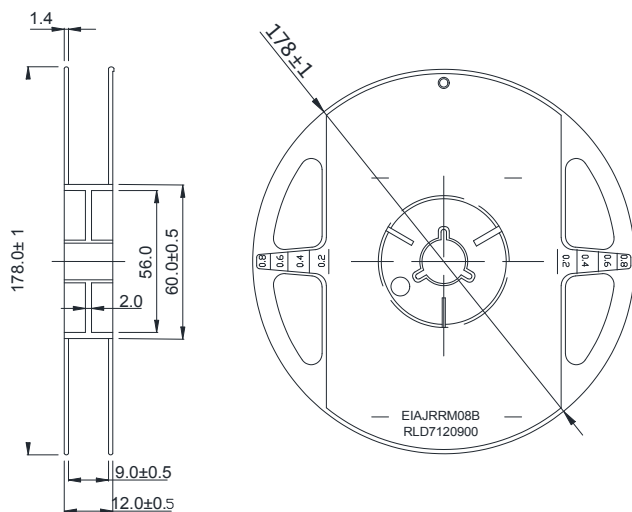

备注：若无特别标注，图中尺寸公差为±0.2mm，单位=mm

Note : Tolerance s unless mentioned ±0.01mm. Unit=mm

回流焊 Reflow

■ 回流焊接：推荐使用以下回流焊接温度图进行

Reflow Soldering: Use the conditions shown in the under Figure o Reflow Soldering.

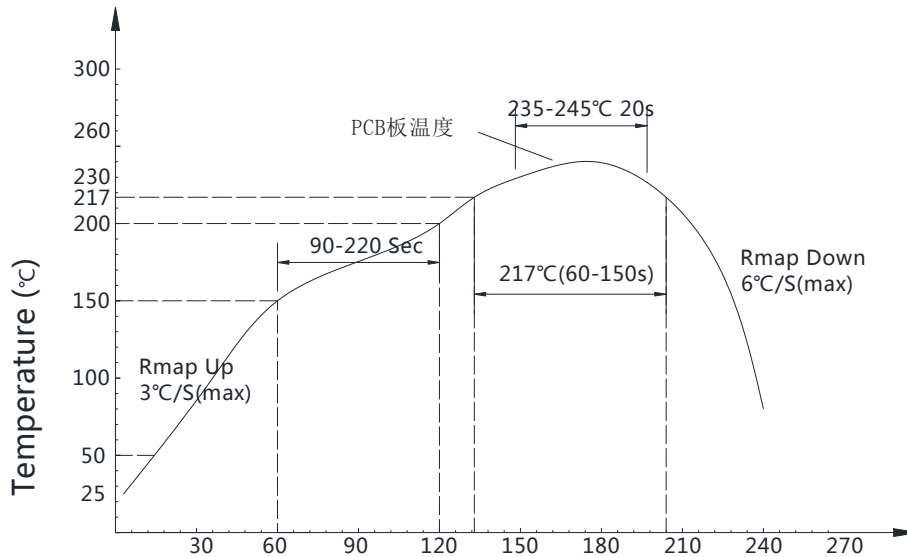

■ 回流焊接 Reflow Soldering

- 回流焊次数不可以超过一次，否则 ALS 可能损坏。

Reflow soldering should not be done more than once, or ALS will be damaged.

- 当焊接时，不要在材料受热时用力压胶体表面。

When soldering, do not put stress on the ALS during heating.

- 建议回流链速：80-100cm/min (回流炉以 8 温区为基准，温区越多建议使用链速更快)

Please be sure the speed of the chain is 80-100cm/min (The reflow furnace is based on 8 temperature zone, the more temperature zone, the faster speed of the chain is recommended.)

■ 烙铁焊接 Soldering iron

- 如使用手工焊接，建议使用小于 25 瓦的电烙铁，烙铁温度必须空置在 300°C 以下，焊接时间需控制在 3 秒钟以内，且每个点击只能焊接一次。

If solder manually, it is recommended to use soldering iron less than 25W. The temperature of the iron must be kept below 300°C. And soldering time should be within 3 seconds, each point can only be soldered once only.

- 当焊接时，不要在材料受热时用力压胶体表面。

When soldering, do not put stress on the LED colloid surface during heating.

- 手工焊接只可焊接一次。

- Manually soldering should be done once only

- 器件外部温度在 40°C 以下时，才可以对其进行处理。避免高温时操作对 LED 造成损伤。

Handing of the SMD LED should be done when the package has been cooled down to below 40°C or less. This is to prevent LED failures due to thermal-mechanical stress during handing.

■ 清洗 Cleaning

- 在焊接后推荐使用酒精进行清洗，在温度不高于 30°C 的条件下持续 3 分钟，不高于 50°C 的条件下持续 30 秒。使用其他类似溶剂清洗前，请先确认使用的溶剂不会对 LED 的封装和陶瓷底座部分造成损伤。

It is recommended that alcohol be used as the solvent for cleaning after soldering. Cleaning should be done under 30°C for 3 minutes or 50°C for 30 seconds. When using other solvents, it should be confirmed beforehand whether the solvents will dissolve the package and the resin or not.

■ 修补 Repairing

- LED 回流焊后不应该修复，当修复是不可避免时，必须使用双头烙铁，但必须事先确认此种方式会或不会损坏 LED 本身的特性。

Repair should not be done after the LEDs have been soldered. When repairing is unavoidable, a double-head soldering iron should be used (as below figure). It should be confirmed in advance the characteristics of LEDs will not be damaged by repairing.

注意：此一般指导原则并不适用于所有 PCB 设计和焊接设备的配置。具体工艺收到诸多因素的影响，请根据特定的 PCB 设计和焊接设备来确定焊接方案。

Note :This general guideline may not suitable for all PCB designs or configurations of all soldering equipment. The technique in practice is influenced by many factors, it should be specialized base on the PCB designs and configurations of the soldering equipment.